

## DN 300 MULTIDO™ Manlid

12" Low profile and Standard manlid

The PEROLO DN300 MULTIDO™ manlid is designed to be installed on containers, road tankers and storage tanks intended for chemical and foodstuff liquid products.



### Specifications

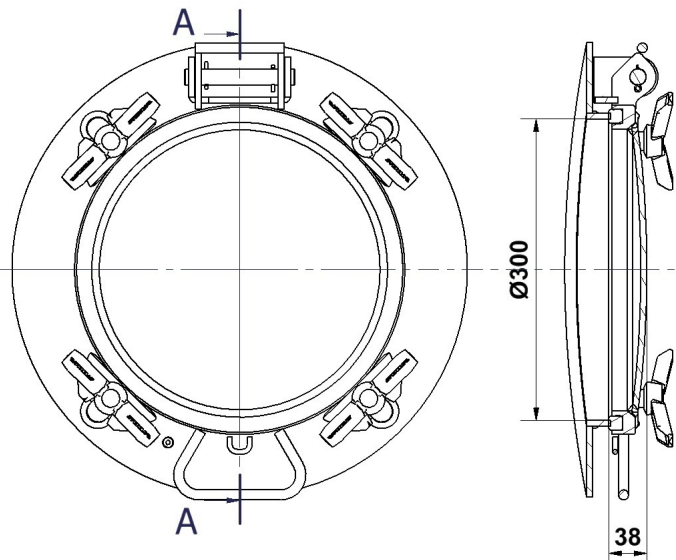

- |                         |              |
|-------------------------|--------------|
| • Nominal Diameter :    | 300 mm (12") |
| • Weight                | 16kg         |
| • MAWP :                | 4 Bar        |
| • Test Pressure :       | 6 Bar        |
| • Designed temperature: | +200°C       |
| • Explosiveness :       | 11 bar       |

### Approval & Certifications

- Approved by Lloyd's Register

### Features

- 316L stainless steel manlid & swingbolts
- Wide range of products for an easy adaptation
- Points fastening: 4
- Smooth machined internal surfaces
- Captivate handnuts
- Thread rolled eyebolts
- Neckring thickness : 6mm.
- Trapezoïdal seal groove for a perfect tightness

### Options

- Material : 316L, 304L or 904L Stainless Steel, S355 carbon Steel
- Low profile, neckring height : from 21 to 34mm
- Standard, neckring height : from 36 to 300mm
- Flush neckring.
- Protusion : from 3 to 6mm or flush neckring
- Radius : from 850 to 1200mm.
- Sealing : Standard or TIR
- Bolts : Standard swingbolts or Safetbolts
- Finishing : Acid Etched, electropolishing or Halar coated

### Accessories

- |                                  |                      |
|----------------------------------|----------------------|
| • 4 points Low profile Coverlid. | Part#11 13 87 10 00. |
| • 4 points Standard Coverlid.    | Part#12 13 58 10 00. |
| • Short eye bolt kit (58mm).     | Part#12 93 86 92 00. |
| • Gasket PTFE Braided 15*14      | Part#11 13 75 00 12. |
| • Hinge kit Stainless steel      | Part#12 13 68 91 00. |

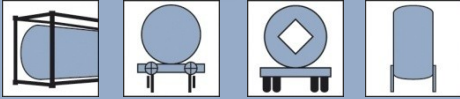

## Codification

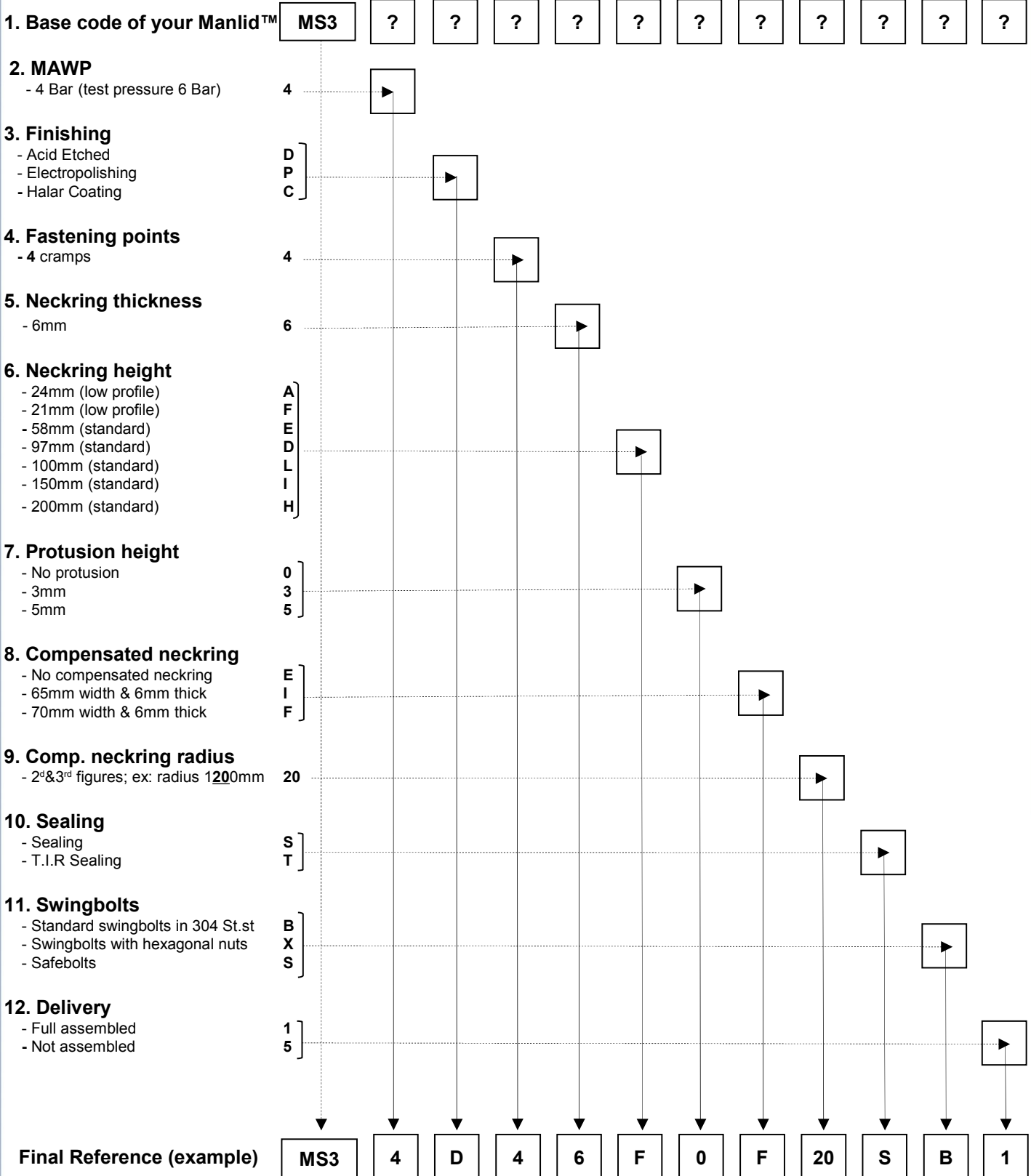

For any specific requests, please feel free to contact our sales department at [sales@perolo.com](mailto:sales@perolo.com)