



3" TANKFLY™ Clamped Series 3" Clamped Butterfly valves

The 3" TANKFLY™ clamped butterfly valve is designed to be clamped between two flanges or directly onto the pipe work.

Made of 316L / 1.4404 stainless steel, the 3" TANKFLY™ valve is applicable to tank containers, rail tanks, road tankers and static tanks dedicated to transporting or storing chemicals and liquid foodstuff.



Specifications

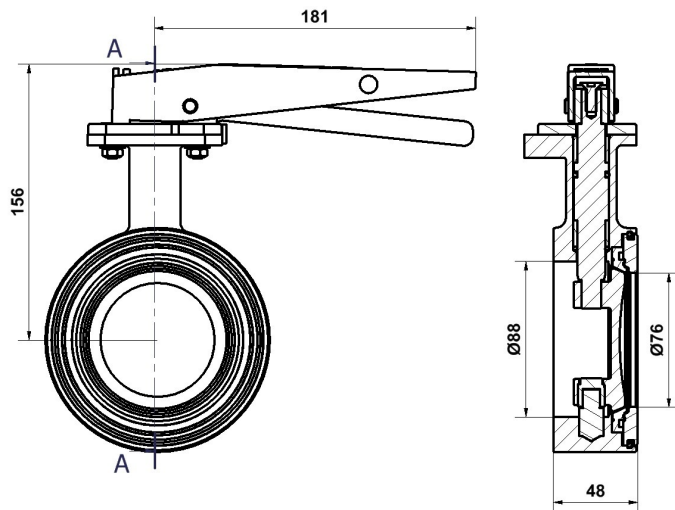

- Nominal diameter: 80mm (3")
- Weight: 3.4 kg
- MAWP: 6 bar
- Test pressure: 8 bar
- Design temperature: 190°C

Approval & Certifications

- Comply with ADR 2008 & IMDG 2009
- Approved by Lloyd's Register
- Comply with EN14432

Features

- Full 316L/1.4404 Stainless Steel construction
- To be clamped between PN, DIN or ANSI flanges
- Compact design, face to face: 48mm
- ¼ turn operation
- FEP/PTFE seals
- Opening torque : 2 daN.m

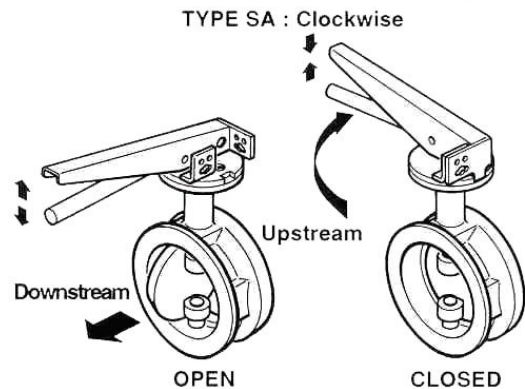

Options & Parts

- 3" TANKFLY™ clamped, standard
Part#11 12 62 00 00
- 3" TANKFLY™ with spindle extension.
Part#11 12 83 00 00
- 3" TANKFLY™ with spherical closure plate.
Part#12 85 57 00 00S
- 3" TANKFLY™ Halar coated + Hastelloy.
Part#11 17 03 00 00.
- 3" TANKFLY™ Halar coated + Hastelloy.
+ ¾" BSP connection.
Part#11 17 04 00 00.